

PI1704

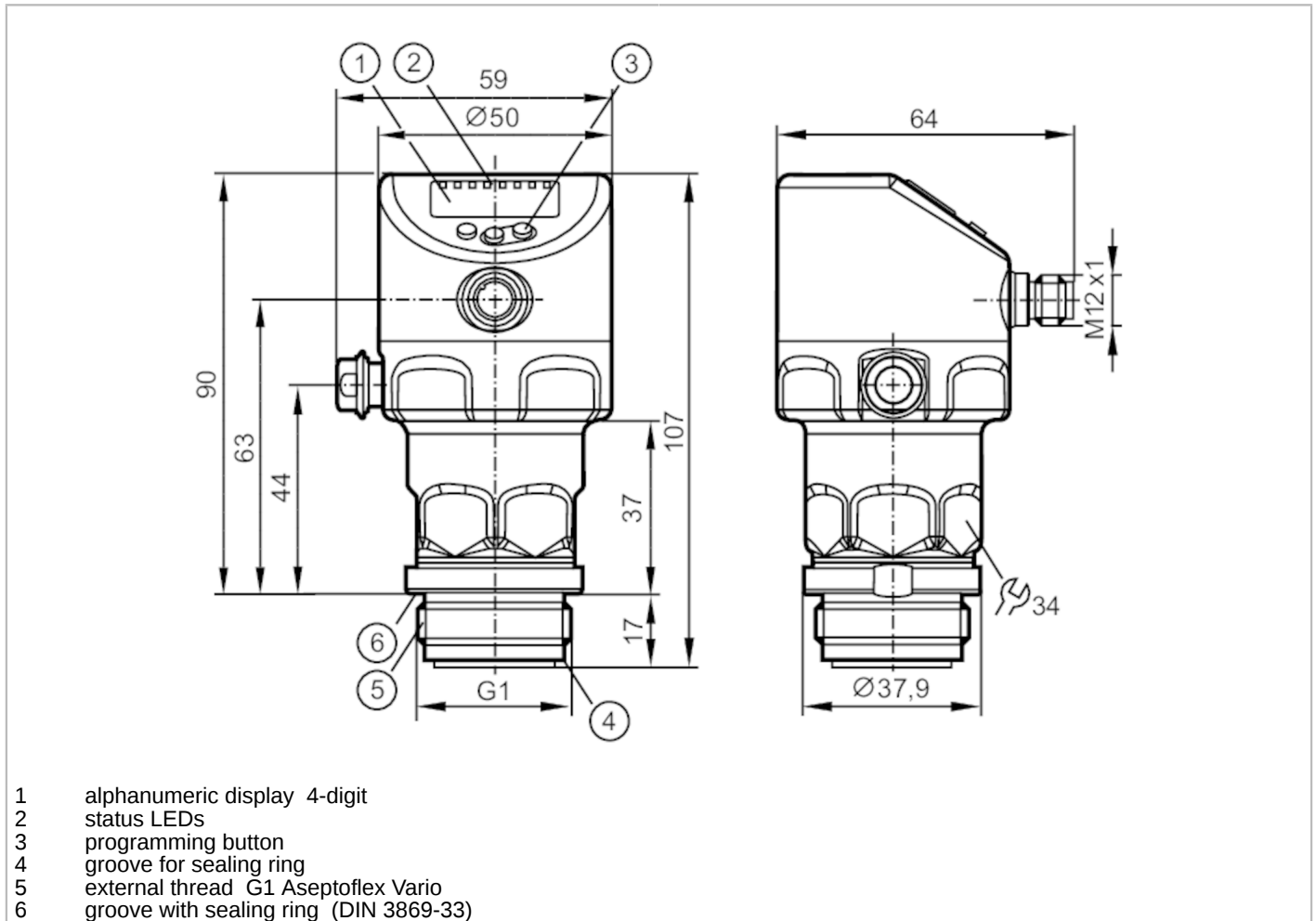

Flush pressure sensor with display

PI-010-REA01-MFRKG/US/ IP



Product characteristics			
Number of inputs and outputs	Number of digital outputs: 2; Number of analogue outputs: 1		
Measuring range	-1...10 bar	-14.6...145 psi	-0.1...1 MPa
Process connection	threaded connection G 1 external thread Aseptoflex Vario		
Application			
Special feature	Gold-plated contacts		
Application	flush mountable for the food and beverage industry		
Media	viscous media and liquids with suspended particles; liquids and gases		
Medium temperature [°C]	-25...150		
Min. bursting pressure	150 bar	2175 psi	15 MPa
Pressure rating	50 bar	725 psi	5 MPa
Vacuum resistance [mbar]	-1000		
Vacuum resistance [MPa]	-0.1		
Type of pressure	relative pressure; vacuum		
No dead space	yes		
MAWP (for applications according to CRN) [bar]	10		

PI1704



Flush pressure sensor with display

PI-010-REA01-MFRKG/US/ IP

Electrical data				
Min. insulation resistance	[MΩ]	100; (500 V DC)		
Protection class		III		
Reverse polarity protection		yes		
Integrated watchdog		yes		
2-wire				
Operating voltage	[V]	20...30 DC		
Current consumption	[mA]	3.5...21.5		
Power-on delay time	[s]	< 1		
3-wire				
Operating voltage	[V]	18...30 DC		
Current consumption	[mA]	5...45; (430 bei max. Laststrom)		
Power-on delay time	[s]	< 0.5		
Inputs / outputs				
Number of inputs and outputs		Number of digital outputs: 2; Number of analogue outputs: 1		
Outputs				
Total number of outputs		2		
Output signal		switching signal; analogue signal; IO-Link		
Electrical design		PNP/NPN		
Number of digital outputs		2		
Output function		normally open / normally closed; (parameterisable)		
Number of analogue outputs		1		
Analogue current output	[mA]	4...20, invertible; (scalable)		
Short-circuit protection		yes		
Type of short-circuit protection		pulsed		
Overload protection		yes		
2-wire				
Max. load	[Ω]	300		
3-wire				
Max. voltage drop switching output DC	[V]	2		
Permanent current rating of switching output DC	[mA]	100		
Switching frequency DC	[Hz]	125		
Max. load	[Ω]	(U _b - 10 V) / 21,5 mA; 650 Ω (U _b = 24 V)		
Measuring/setting range				
Measuring range		-1...10 bar	-14.6...145 psi	-0.1...1 MPa
Set point SP		-0.99...10 bar	-14.3...145 psi	-0.099...1 MPa
Reset point rP		-1...9.99 bar	-14.5...144.8 psi	-0.1...0.999 MPa
Analogue start point		-1...8 bar	-14.5...116 psi	-0.1...0.8 MPa
Analogue end point		1...10 bar	14.5...145 psi	0.1...1 MPa
Min. difference between SP and rP		0.02 bar	0.3 psi	0.002 MPa
In steps of		0.01 bar	0.1 psi	0.001 MPa

PI1704



Flush pressure sensor with display

PI-010-REA01-MFRKG/US/ IP

Factory setting	SP1 = 2.50 bar	rP1 = 2.30 bar
	SP2 = 7.50 bar	rP2 = 7.30 bar
	ASP = 0.00 bar	AEP = 10.00 bar
	dAP = 0.06 s	dAA = 0.06 s

Temperature monitoring		
Measuring range	-25...150 °C	-13...302 °F

Accuracy / deviations

Switch point accuracy [% of the span]	< ± 0,2; (DIN EN IEC 62828-1; Turn down 1:1)	
Repeatability [% of the span]	< ± 0,1; (with temperature fluctuations < 10 K; Turn down 1:1)	
Characteristics deviation [% of the span]	< ± 0,2; (DIN IEC EN 62828-1 incl. zero point and span error, non-linearity, hysteresis; Turn down 1:1)	
Linearity deviation [% of the span]	< ± 0,15; (Turn down 1:1)	
Hysteresis deviation [% of the span]	< ± 0,15; (Turn down 1:1)	
Long-term stability [% of the span]	< ± 0,1; (Turn down 1:1; per year)	
Total deviation over temperature range	Temperature range	total deviation
	-25...15 °C	Characteristics deviation ± 0,05 % of the span / 10 K
	15...80 °C	Characteristics deviation
	80...150 °C	Characteristics deviation ± 0,1 % of the span / 10 K
Notes on the accuracy / deviation	for further details see section Diagrams and graphs	

Temperature monitoring		
Accuracy [K]	± 2,5+ (0,08 x (Umgebungstemperatur - Mediumtemperatur))	
Repeatability [K]	± 0,2	
Resolution [K]	0.2	

Response times

Damping process value dAP [s]	0...99.99
Damping for the analogue output dAA [s]	0...99.99

2-wire		
Step response time analogue output [ms]	30	

3-wire		
Min. response time of switching output (dAP) [ms]	3	
Step response time analogue output [ms]	7	

Temperature monitoring		
Dynamic response T05 / T09 [s]	< 35 / < 135; (DIN EN 60751 water ; > 0,9 m/s)	

Interfaces

Communication interface	IO-Link	
Transmission type	COM2 (38,4 kBaud)	

PI1704



Flush pressure sensor with display

PI-010-REA01-MFRKG/US/ IP

IO-Link revision	1.1	
SDCI standard	IEC 61131-9	
Profiles	Function class	Designation
	0x4000	Identification and Diagnosis
	0x800A	Measurement Data Channel (standard resolution)
SIO mode	yes	
Required master port type	A	
Min. process cycle time [ms]	5.6	
IO-Link resolution pressure [bar]	0.0005	
IO-Link resolution temperature [K]	0.2	
IO-Link process data (cyclical)	function	bit length
	pressure	32
	temperature	32
	device status	4
	binary switching information	2
IO-Link functions (acyclical)	application specific tag; internal temperature; operating hours counter; switching cycles counter; Pressure peak counter	
Supported DeviceIDs	Type of operation	DeviceID
	default	1156

Operating conditions		
Ambient temperature [°C]	-25...80	
Storage temperature [°C]	-40...100	
Protection	IP 67; IP 68; IP 69K	

Tests / approvals		
EMC	DIN EN 61326-1	
Shock resistance	DIN EN 60068-2-27	50 g (11 ms)
Vibration resistance	DIN EN 60068-2-6	20 g (10...2000 Hz)
MTTF [years]	214	
Note on approval	factory certificate available as download at www.factory-certificate.ifm	
UL approval	UL Approval no.	J048
	File number UL	E174189

Mechanical data		
Weight [g]	360	
Housing	cylindrical	
Dimensions [mm]	Ø 50 / L = 107	
Materials	stainless steel (316L/1.4404); FKM; PTFE; PBT; PEI; PFA	
Materials (wetted parts)	ceramics (99.9 % Al ₂ O ₃); stainless steel (316L/1.4435); surface characteristics: Ra < 0,4 / Rz 4; PTFE	
Min. pressure cycles	100 million	
Tightening torque [Nm]	35	
Process connection	threaded connection G 1 external thread Aseptoflex Vario	

PI1704



Flush pressure sensor with display

PI-010-REA01-MFRKG/US/ IP

Displays / operating elements

Display	Display unit	LED, green
	switching status	LED, yellow
	function display	alphanumeric display, 4-digit
	measured values	alphanumeric display, 4-digit
Display unit	bar; psi; MPa	

Remarks

Pack quantity	1 pcs.
---------------	--------

Electrical connection

Connector: 1 x M12; coding: A; Contacts: gold-plated





Flush pressure sensor with display

PI-010-REA01-MFRKG/US/ IP

Connection

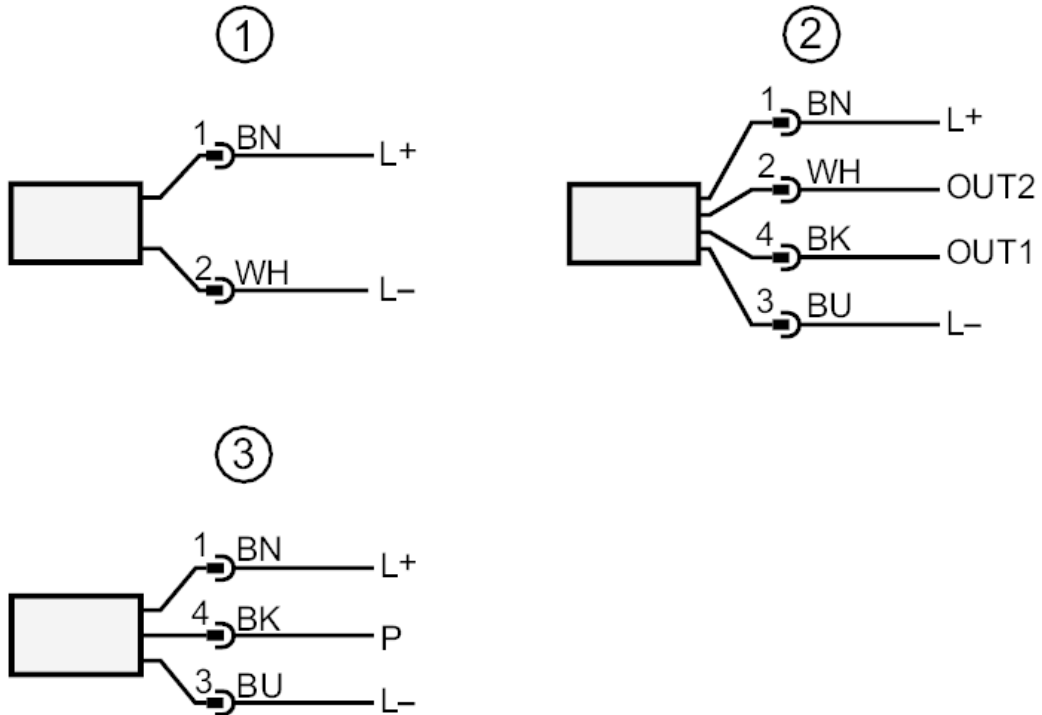

- 1 connection for 2-wire operation
- 2 connection for 3-wire operation
- OUT1 switching output / IO-Link
- OUT2 switching output / analogue output
- 3 connection for IO-Link parameter setting (P = communication via IO-Link)
- colours to DIN EN 60947-5-2
- Core colours
- BK = black
- BN = brown
- BU = blue
- WH = white

PI1704



Flush pressure sensor with display

PI-010-REA01-MFRKG/US/ IP

Diagrams and graphs

ambient temperature influence on the accuracy

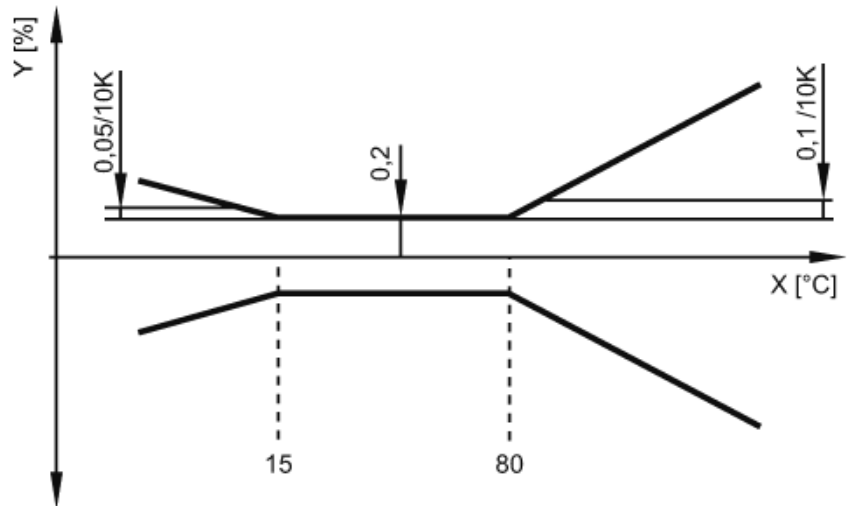

X temperature
Y total deviation